

1 Wagner Punch Tech Measuring and Ejectors

Title: *Measuring and Punch Ejectors and Tips*



Article # 01-12-A

Micrometer Measuring Attachment

One of the most difficult tasks in diemaking is to measure punches and steel rule accurately and consistently. No matter how you hold the damn thing it is rarely precise or accurate (see Illustration 1). It is therefore a pleasure to recommend an elegant device, which is specifically designed to solve this dilemma.

Fast-Easy Punch/Steel Rule Quality Control

The attachment designed and made by **Bar-Plate**, and sold by Wagner Die Supply. The attachment is light and easy to handle as it is designed to slip onto the barrels of a standard micrometer (See illustration 2). When a punch or steel rule is positioned in the tool; it enables perfect alignment and the male and female micrometer barrels to the punch or rule being measured.

In fact the device can be used with full lengths of knife or coils as the attachment can slide along the knife or the knife can slide through the attachment. This enables fast, accurate measurement of multiple locations along a length of rule.

The V-Groove in the center of the attachment is designed to hold punches and the punch can be rotated in the attachment, to enable multiple measurements of the edge.

Summary

This is an essential tool for every diemaker, as it is easy to use, it is fast, and it is very effective. This inexpensive device will minimize using the wrong height knife, punch, crease, score, or perforation rule, and it will enable a precision check of rule quality parameters, quickly and easily. Contact your Wagner Die Supply location to order your Micrometer Measuring Attachment today!

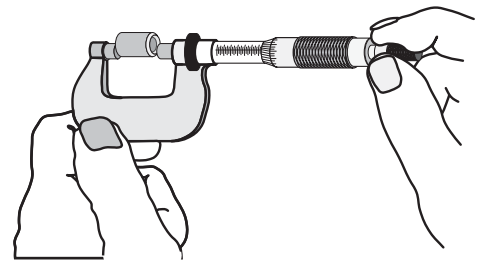

Illustration 1.

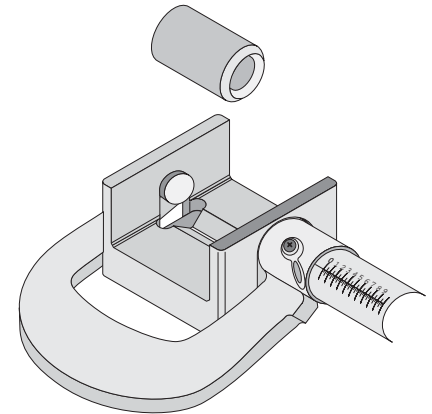

Illustration 2.

Helping Cup Punches Eject

Under normal circumstances, cup punches eject material well without the need of any ejectors. However, in applications where the diecut slug is required to stay in place with the diecut part, and adding a nick is not desirable, to improve the degree of slug control, it is often useful to add a small bead of Silicone Rubber to the center of the cup. (See illustration 3).

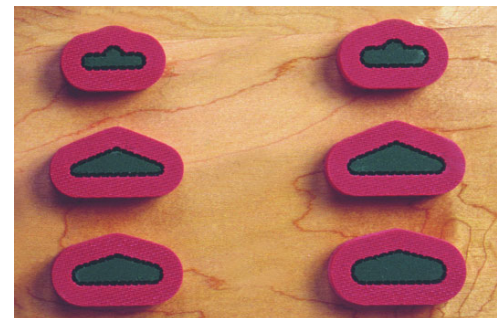

Illustration 3.



Exceptional Punch Ejectors

Monroe Rubber and Plastic, developed two extraordinary ejection materials, Green Grill'a & Red Rhino. These materials rapidly established a great reputation for consistent on-press performance and problem solving. But did you know they WaterJet a range of superb punch ejectors? Wagner Die Supply carries a full line of water jet ejectors specifically designed for use with Wagner Punches. Like our famous Wagner Seamless Hangers! Call your Wagner Die Supply location for more information.



For more information, please contact us at:

(800) 423-4478 toll free

or visit our website at

www.wagnerdiesupply.com



Wagner Die Supply
Diemaking & Diecutting Source & Resource

Ontario, CA • Tacoma, WA • Dallas, TX • Elmhurst, IL

2041 Elm Court, Ontario, California 91761